



SOLAR G

Dry coolers

General information & application

Dry coolers are often used for cooling down condenser water in air conditioning and refrigeration installations. In the processing industry, dry coolers are suitable for closed circuit cooling of various process liquids. With a wide range of sound pressure level alternatives, these units are particularly suited to demanding, noise sensitive environments.

Capacities* 37 up to 1651 kW

* water, EN1048.

Coil

Coil manufactured from copper tubes \varnothing 12.7 mm and corrugated Alu-fins, tube pitch 35 x 30.31 mm. Standard fin spacing is 2.3 mm.

Casing

Casing and framework of corrosion resistant, hot dip galvanised sheet steel.

Fan motors

1 to 14 axial fans available in a range of different fan speed executions, diameters 914 or 1240 mm. Enclosed design fan motors, protection class IP-54, class F insulation.

Motors are wired to the fans' safety switches (IP65). All fans have corrosion resistant fan blades and fan guards.

Certifications

All dry cooler models are "Eurovent Certify All" certified. The Alfa Laval Vantaa quality system is in accordance with ISO 9001. All products are manufactured according to CE and PED rules.

Test

Design pressure 6 barg. Each heat exchanger is leak tested with dry air.



SOLAR G

Options

- Multi-circuiting (J#)
- Copper (CC) or epoxy coated (Ep) fins
- Fin spacing 3 mm
- Water spraying system (D)
- Vibration dampers (T)
- Step control (SC)
- Fan speed control with frequency converter (SVC)
- Casing epoxy painted grey RAL 7040 (MU, M1, M2, M3)
- EMC cables, glands & safety switches for each fan (EMC)
- Motors with thermal overload Klixon switches (THC)
- Motor heater (MH)
- Fans wired to connection box (TB)
- Forced draught (FD)

Dry cooler selection & dimensions

Dry cooler selection is to be performed with our 'FincoilSelect' Air Heat Exchanger selection software. Selection output includes all relevant technical data and dimensional drawings.



Dimensions & weights

coil size	dimensions (mm)					fixing points	weight kg	int.vol. l	surface m ²
	L	C	C1	C2	C3				
111	2000	1400	1400			4	240	30	160
112	2000	1400	1400			4	260	40	213
113	2400	1800	1800			4	320	50	274
121	3400	2800	2800			4	480	50	320
122	3400	2800	2800			4	520	70	426
123	4200	3600	3600			4	640	90	548
131	4800	4200	4200			4	720	80	480
132	4800	4200	4200			4	780	100	640
133	6000	5400	5400			4	960	130	822
141	6200	5600	2800	2800		6	960	100	640
142	6200	5600	2800	2800		6	1040	140	852
143	7800	7200	3600	3600		6	1280	170	1100
151	7600	7000	2800	4200		6	1200	130	800
152	7600	7000	2800	4200		6	1300	170	1070
153	9600	9000	3600	5400		6	1600	210	1370
221	4200	3600	3600			4	920	100	616
222	4200	3600	3600			4	990	140	822
223	4800	4200	4200			4	1110	150	960
231	6000	5400	5400			4	1370	150	924
232	6000	5400	5400			4	1490	200	1230
233	6900	6300	6300			4	1670	230	1440
241	7800	7200	3600	3600		6	1830	200	1230
242	7800	7200	3600	3600		6	1980	260	1640
243	9000	8400	4200	4200		8	2200	300	1920
251	9600	9000	3600	5400		8	2280	240	1540
252	9600	9000	3600	5400		8	2470	320	2060
253	11100	10500	4200	6300		8	2770	370	2400
261	11400	10800	3600	3600	3600	8	2730	290	1850
262	11400	10800	3600	3600	3600	8	2970	380	2470
263	13200	12600	4200	4200	4200	8	3320	450	2880
264	11400	10800	3600	3600	3600	8	3200	480	3080
265	11400	10800	3600	3600	3600	8	3430	570	3700
266	13200	12600	4200	4200	4200	8	3590	550	3600
267	13200	12600	4200	4200	4200	8	3860	660	4320
271	13200	12600	3600	5400	3600	8	3190	340	2160
272	13200	12600	3600	5400	3600	8	3460	450	2880
273	13200	12600	3600	5400	3600	8	3730	550	3600
274	13200	12600	3600	5400	3600	8	4000	660	4320

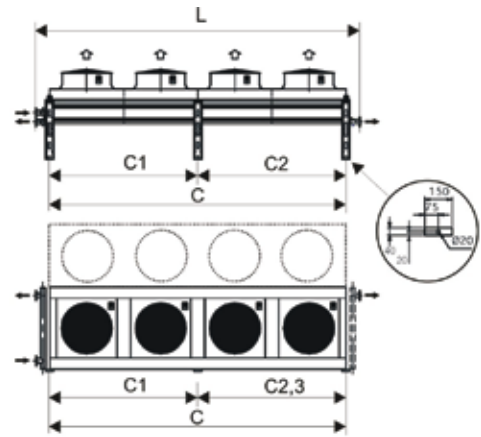

Models 111 to 153

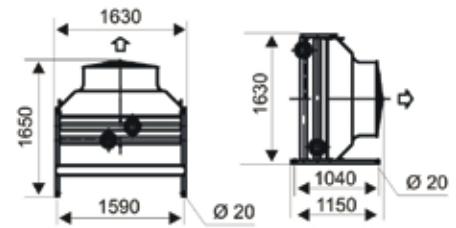

Models 221 to 274

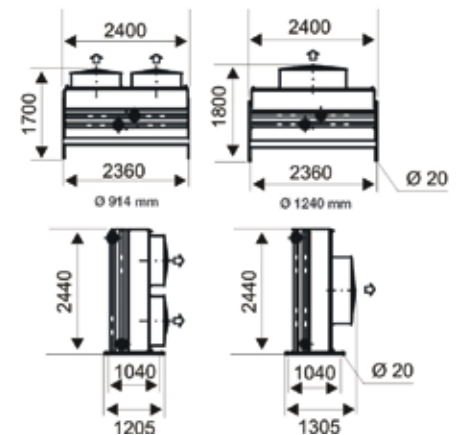

Code description

SCAGE - 221 - 09 - 06N5 - H - 32 - 2DN100 - Options

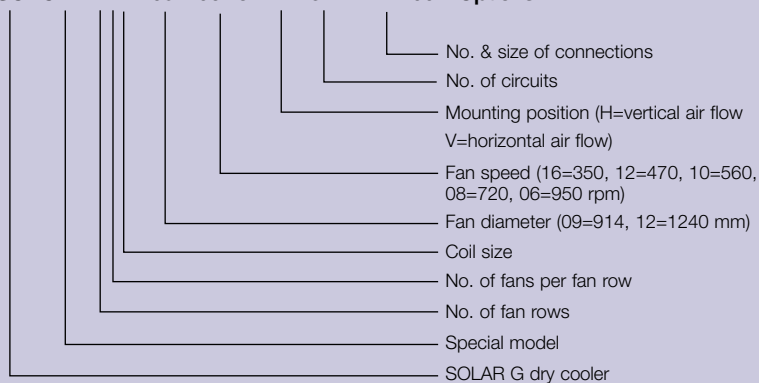

Benefits

- Heavy duty coil & casing materials, resulting in a long operational product life.
- Floating coil construction to compensate for thermal stress.
- Plain profile fins make the coil less prone to fouling and easier to clean.
- Excellent sound characteristics
- Reliable performance, Eurovent certified.
- Easy-install & maintenance.
- Energy efficient - low total cost of ownership.
- One full year product guarantee.

ERC00138EN 0809

Alfa Laval reserves the right to change specification without prior notification.

How to contact Alfa Laval

Up-to-date Alfa Laval contact details for all countries are always available on our website at www.alfalaval.com

